

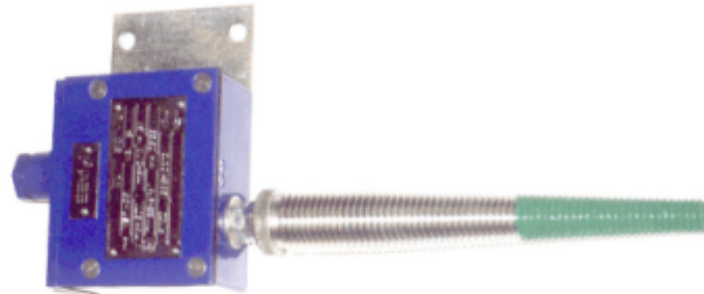

VSP-3B omnidirectional sensor



Use:

The sensors are designed to signalize the position of slowly moving devices or objects. The signaling is made by switching the galvanically separated switching contact of the microswitch.

Description:

The base of the VSP-3B sensor is the case with a microswitch and leverage. The sensor is formed by a bowden protected by a spring. If the bowden deflects a certain angle in any direction, the lever will operate the microswitch. The deflection angle sensitivity is adjustable from outside within the range 30 to 80 without the necessity of disassembling the device. The sensor can be mounted in any position, because it will return to the starting position after removal of actuating force.

The sensors may be connected to an intrinsically safe circuit if the remaining elements of the circuit are corresponding and if limit inductance and capacity values of the connecting cable between the sensor and the intrinsically safe device with these values specified are not exceeded.

Technical parameters:

Switched voltage	2.5 90 VDC/AC
Switched current	0.0005 0.1 ADC/AC
Load character	resistive load
Maximum switching rate	1s ⁻¹
Maximum bowden deflection angle	95°
Protection	IP 54
Construction	EExi I
Operating temperature	-20 to +40°C
Relative humidity	max. 95%

The catalogue has only those selected important parameters for your final decision. For project designs always ask for the user's guide for this product and any engineering consultation about possible uses.



ET-4/1-L deflection switch



Description:

Deflection switches are mounted on conveyor belts to minimize the risk of damaging or destroying the belt caused by it deflecting from the path.

ET-4/1-L deflection switches are designed for longitudinal mounting on smaller conveyors. They are placed in pairs on both the right and the left side of the belt. If the belt deflects from its track, its edge will push back the cylindrical lever of the switch against the inner spring tension. If the deflection angle reaches 25°, the switch-over will occur. The maximum deflection of the cylindrical lever is 55°. As soon as the belt returns to the correct position, the cylindrical lever will follow this movement and switch back as soon as the deflection angle is c. 16°. For easy mounting, the cylindrical lever can be mounted at any angle.

Use:

Deflection switches are mounted on conveyor belts to minimize the risk of damaging or destroying the belt caused by it deflecting from the path.

ET-4/1-L deflection switches are designed for longitudinal mounting on smaller conveyors. They are placed in pairs on both the right and the left side of the belt. If the belt deflects from its track, its edge will push back the cylindrical lever of the switch against the inner spring tension. If the deflection angle reaches 25°, the switch-over will occur. The maximum deflection of the cylindrical lever is 55°. As soon as the belt returns to the correct position, the cylindrical lever will follow this movement and switch back as soon as the deflection angle is c. 16°. For easy mounting, the cylindrical lever can be mounted at any angle.

The roller of the cylindrical lever is mounted in a slide assembly on the shaft (axis) from fine steel and is made of polyamide with a portion of graphite. Due to this composition, the service life of the roller is much longer than that of a white polyamide roller without graphite. The roller diameter can be 20 mm or 32 mm by request. The advantage of the thinner roller is the possibility of use in small area conditions, while the advantage of the thicker roller is its lower rotating speed for the same belt speed. Both roller types, especially the thicker one, have the biggest outside diameter-axis diameter ratio compared to similar products. This is very important for easily putting into operation, e.g. if the device has not been used for some time and the rollers are seized due to impurities, dust, or ice. If it be to the contrary, the outside of the roller would be worn by the edge of the belt. The case is made of pressure aluminium alloy and its degree of protection is IP 65.

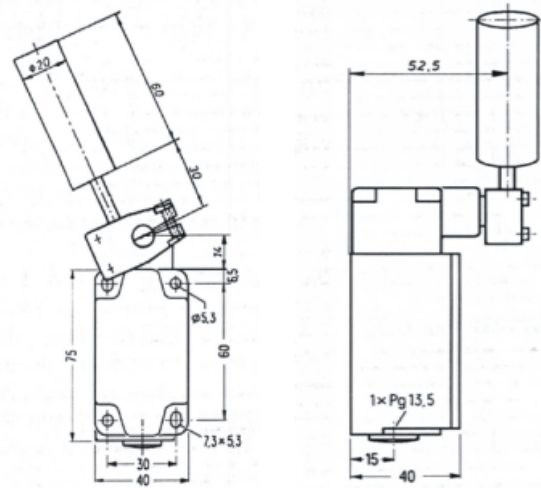

Type	Description
ET-4/1-L	Deflection switch with a 20 mm diameter roller
ET-4/1-L32	Deflection switch with a 35 mm diameter roller

Technical parameters:

Switching angle	25°
Max. deflection	55°
Switching elements	34mm
Switching force	1 operating contact and 1 break contact
Load capability of the contacts	240 VAC 6 A or 24 VDC 5 mA - 10A
Lead outlet	1 x PG 13.5 hole with thread
Protection	IP 65
Case (housing) material	aluminium pressure alloy
Case colour	yellow RAL 1003
Weight	0,3kg
Temperature range	-40°C to +85°C

The catalogue has only those selected important parameters for your final decision. For project designs always ask for the user's guide for this product and any engineering consultation about possible uses.